



**GREYFIELD  
INDUSTRIES, INC.**

**LEADER IN AUDIO/VIDEO TECHNOLOGY**

# **Product Information**

- 1. Product Overview Brochure**
- 2. Audio Console**
  - **Brochure**
  - **Features/Instructions**
- 3. 1 or 2 Lane Audio Kit**
  - **Brochure**
  - **Feature/Instructions**
- 4. Video**
  - **Brochure**
  - **Features/Instructions**
- 5. Wireless Audio Console**
  - **Brochures**
  - **Features/Instructions**
- 6. Audio & Video Accessories Brochures**
- 7. FAQ for Audio & Video**

# Greyfield™

The Latest  
Audio/Video Technology

## Audio/Video Communications Systems

help keep customer lines moving at:

- Financial Institutions
- Quick-serve restaurants
- Drive-up pharmacies
- Convenient Mart/Service Stations



### Greyfield Audio/Video Systems

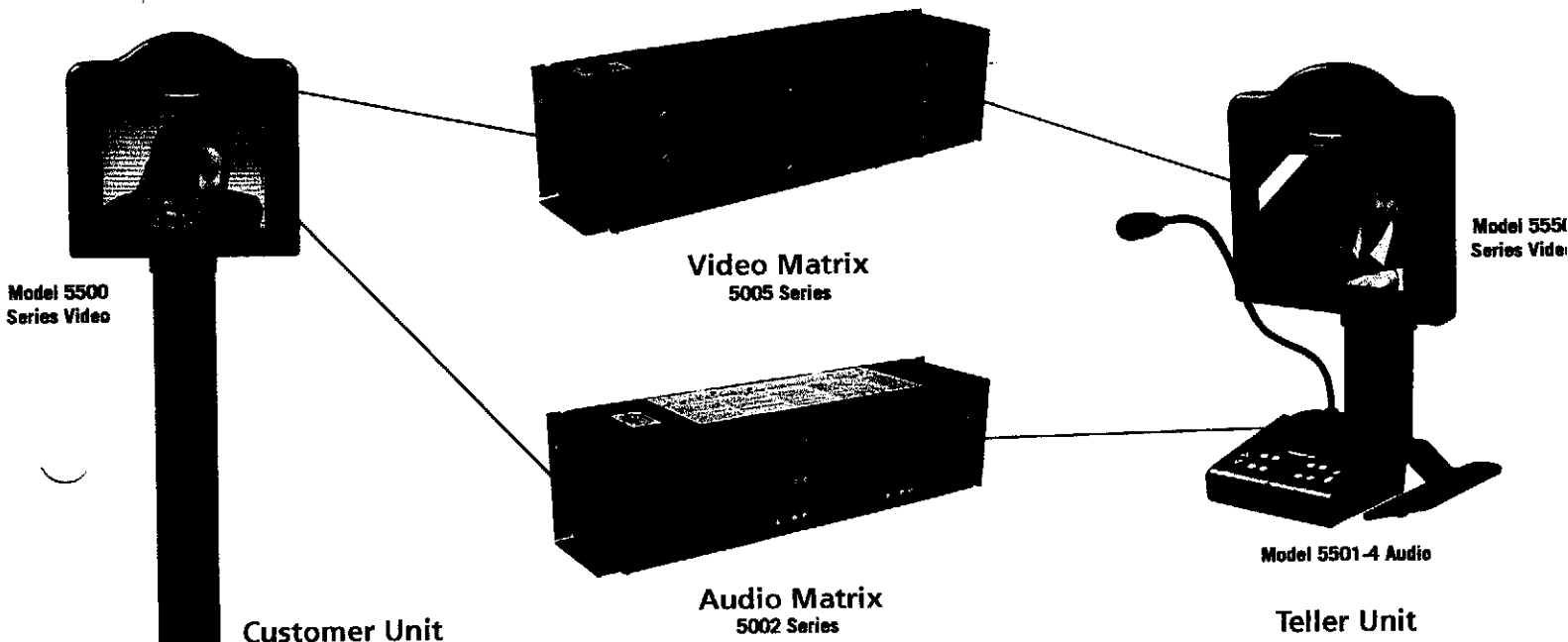

# Greyfield Audio/Video Components



## 5016 Lightweight Wireless Headset

### Model CS-50 Headset

- Allows hands-free communication
- Provides communication even when your service representative must move out of your customer's line of site
- Slim and lightweight with nothing attached to your belt

## Series 5501 Audio and 5550 Video

- Audio console available in 2, 4, 8 and 12 lane models
- Noise cancellation feature reduces loud vehicle noise for clear communication
- Quick-change color strip to easily color code lanes
- Auto-Greeter permits recording up to 4 different messages to your customers
  - Keeps your customer occupied while they are waiting
  - Advertise specials and promotions
  - Welcome a customer while serving other customers
- Resilient spill proof keypad tested for 2-million touches
- High-resolution video screen

## Greyfield develops audio and video technology to keep the lines moving

- Clear Audio
- Hands-free wireless system
- Technical support & repair
- Customized for your needs
- Audio and video serves multiple lane installations

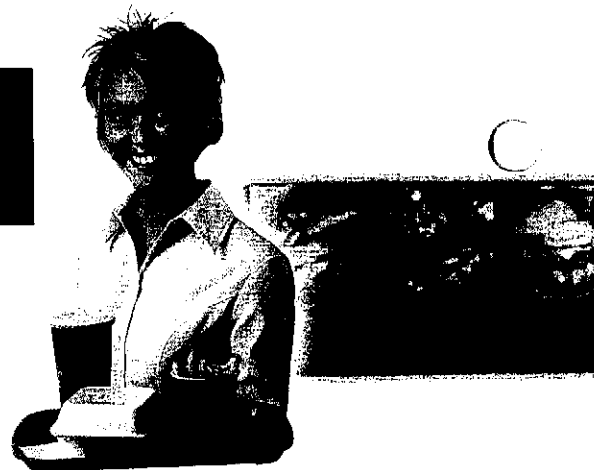

## About Greyfield

Greyfield Industries Inc. has been manufacturing state-of-the-art communications for more than thirty years. Enjoying tremendous success in the banking industry, hundreds of thousands of Greyfield systems are in service at drive-up installations across the nation and around the world. Our engineering staff also designs sound systems for quick serve industry, pharmaceutical drive-up windows and gasoline service stations.

We have the capability to customize systems for your operation. We also maintain a full-time staff of technicians ready to assist in troubleshooting and equipment installation.

**Greyfield**<sup>TM</sup>  
manufacturing the latest in audio/video technology in drive-up services

Greyfield Industries, Inc.  
3104 Wayne-Madison Road  
Trenton, Ohio 45067  
Phone: (513) 860-1785  
Fax: (513) 988-9521  
[www.greyfieldindustries.com](http://www.greyfieldindustries.com)

# Audio Console

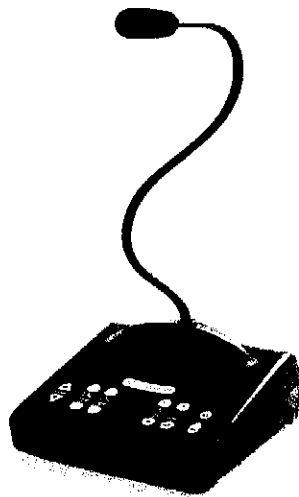

- **G5501-2, G5501-4, G5501-8 & G5501-12**
- **Available in 2, 4, 8 and 12 lane versions**
- **Background Noise Cancel button**
- **Wireless Headset ready – no adaptor necessary**
- **Handset ready – Handset Kits available**
- **Water resistant Membrane Keypad**
- **Supports optional Auto-Greeter Board**
- **Optional wall mounting brackets or desktop stand available**



Greyfield Industries, Inc.  
3104 Wayne-Madison Road, Trenton, Ohio 45067  
Phone: 513-860-1785  
Fax: 513-988-9521  
[www.greyfieldindustries.com](http://www.greyfieldindustries.com)

# 5501 AUDIO CONSOLE FEATURES

**Membrane Keypad:** The 5501 console incorporates a membrane keypad for improved reliability. While this keypad will have a long life under normal use, to avoid damage to the membrane DO NOT use ink pens, fingernails or other sharp objects to operate the keys. Lane colors show through clear windows in the keypad. Colors can easily be changed by sliding out the lane indicator stick from the edge of the console and changing the colored stickers as required.

**Wireless Headset Support:** The 5501 console has built-in support for wireless headsets (e.g. Plantronics CS50). The wireless base unit plugs directly into the phone cable jack on the console located next to the matrix cable jack. This eliminates the need for the 5014 Wireless Interface Adapter. Pressing the WIRELESS key while no lane is selected toggles the unit between console and wireless mode. Wireless mode is indicated by the LED next to the wireless key.

**Echo Canceller & Background Noise Cancellation:** When an audio matrix is powered up, or when a teller console is plugged in with power already applied to the matrix, the complete audio system goes through an initialization process indicated by all console lights flashing red several times, turning solid green, and then turning off. During this process each console reads the status of dip switches 7 & 8 from the matrix and their audio processors are set accordingly. The following items describe these switch combinations when used with the 5501 console. Be sure to cycle power to the matrix when changing these switch settings.

Matrix Switch 7 UP .....DYNAMIC Echo Canceller Learning (Factory Setting)  
Matrix Switch 7 DOWN .....FIXED Echo Canceller Learning

Echo cancellation works by comparing outgoing and incoming audio using a set of parameters. The echo canceller can have either dynamic or fixed learning. Dynamic learning adjusts to its environment each time a teller selects a lane whereas fixed learning stays at a factory preset value. Dynamic learning can cause what some people describe as “robot voice” in certain environments when the lane is initially selected and then clears up after “learning” has been accomplished which could take a few seconds. If the customer complains of audio quality changing between bad and good in this manner, set the learning to “fixed”. Note that when learning is “fixed” there is more of a tendency for the teller to hear their own voice coming back through the console speaker. This condition will be worse with higher settings of the speaker/mic pots on the matrix or when customer units have their speaker and microphone in close proximity to each other.

Matrix Switch 8 DOWN .....Background Noise Cancellation ON (Factory Setting)  
Matrix Switch 8 UP .....Background Noise Cancellation OFF

Background noise comes from a variety of sources but the most common are vehicle noise at the customer lane and general traffic noise from a nearby street. The background noise filtering in the 5501 consoles works well to reduce constant and consistent sounds (i.e. idling vehicles) but has more trouble when the noise is constantly changing, such as traffic noise. This type of noise will generally cause a side effect in the audio processor that most people describe as an under water or gurgling sound. Vehicles sitting in front of a deal drawer have also been known to cause this symptom at some locations due to the sound bouncing between the building and vehicle and this may not occur with all vehicles. The symptom gets worse as the gains on the matrix pots are increased, the volume adjustment on the console is increased, or the level of the background noise increases due to conditions such as heavier traffic or the presence of large trucks. Note that even when this “watery” symptom is present the customer’s voice at the lane is not affected.

Even though background noise cancellation works fine for most installations there are cases it may be preferable to turn it off. If the system is near a busy street for example, the watery sound may be excessive. This could be especially annoying to the tellers if they are leaving a lane selected at all times to hear a customer drive up. Keep in mind that while turning background noise cancellation off will get rid of the “water” sound it will also allow all background noise to be heard, including a noisy vehicle at the lane.

Regardless of the dip switch 8 setting, background noise cancellation can be toggled on or off “on the fly”. On all but the 12 lane version, pressing the Noise Cancel button toggles this feature on (green LED) or off (red LED). With the 12 lane version press the volume up key while no lane is selected to toggle the feature which is indicated by the LED’s for lanes 1 & 3 (green = on & red = off). Changes of this feature made from a console only apply to that particular console and will always revert back to the current setting of dip switch 8 from the matrix whenever the system goes through another initialization process, such as following a momentary power outage. For this reason the technician should select the dip switch setting that corresponds to the most common setting used by the tellers.

**Auto-Greeter Board Support:** The optional auto-greeter board allows up to 4 messages to be easily recorded (or re-recorded). Any one of the 4 messages can be set as the “active” message. After a customer presses the call button, selecting that lane from the teller console automatically plays the current active message. This is called the “auto-greeter” feature and is available on all versions of the console. The auto-greeter board also has a “message-player” feature that is available on all consoles except the 12 lane version. The message-player allows any of the first 3 recorded messages to be played at a selected lane at any time by use of function keys labeled F1, F2 & F3 on the console keypad.

**OPERATING INSTRUCTIONS  
MULTI-LANE 5501 SERIES AUDIO CONSOLE**

Each Lane Key has an indicator light. Interpret the lights as follows:  
 RED (fast flash) = Customer CALLING for service  
 GREEN (steady) = Customer in 2-WAY CONTACT with your console  
 RED (steady) = Customer in 2-WAY CONTACT with another console  
 GREEN (slow flash) = Customer placed on HOLD from your console  
 RED (slow flash) = Customer placed on HOLD from another console



← Puncture Dot to Trim  
Console Mic Gain

**Operate Teller Console as follows:**

- To CONTACT a customer calling ..... Press the LANE key
- To place a customer on HOLD ..... Press the HOLD key (Indicator blinks)
- To CONTACT a customer on hold ..... Press the LANE key
- To END contact with customer ..... Press the active LANE key
- To CANCEL hold and END contact ..... Press the LANE key twice
- To TALK OVER a customer ..... Hold down the active LANE key
- To adjust inside volume (changes made in steps) ..... Press ▲ or ▼ VOLUME key
- To toggle between console & wireless headset ..... Press WIRELESS key (no lane selected)  
Yellow light on = wireless mode
- To adjust outside camera tilt (if option is installed) ..... Hold WIRELESS key and press ▲ or ▼ key
- To view outgoing auxiliary video program ..... Press HOLD & ▼ keys (no lane selected)
- To view yourself ..... Press HOLD key (no lane selected)
- To toggle background noise cancellation (all but 12 lane console) .. Press NOISE CANCEL button  
On or Off (indicated by Noise Cancel light)      Green = On    Red = Off
- To toggle background noise cancellation (12 lane console) ..... Press VOLUME ▲ key (no lane selected)  
On or Off (indicated by Lanes 1 & 3 lights)      Green = On    Red = Off

- Notes:**
- 1) You can contact any customer who is on HOLD from any teller console.
  - 2) Your audio system may be configured to allow any two consoles to contact the same lane simultaneously.
  - 3) To prevent loss of sound quality, avoid selecting unused lanes.
  - 4) To eliminate "watery" background sound turn background noise cancellation off. Doing this will allow a higher level of engine noise and other environmental noises.
  - 5) See separate instructions for Wireless Headset or Auto Greeter (if installed)

HFEA-OI5501 (062906)

# 1 or 2 Lane Audio Kit G5501-1



- **Includes Console, Matrix, cable and power supply**
- **Comes with 2 Lane Console, Micro Matrix, cable & Power Supply**
- **Background Noise Cancel button**
- **Wireless headset ready – no adaptor necessary**
- **Handset ready – Handset Kits available**
- **Water resistant Membrane Keypad**
- **Optional wall mounting brackets or desktop stand available**
- **Supports optional Auto-Greeter Board**

Greyfield Industries, Inc  
3104 Wayne-Madison Road, Trenton, Ohio 45067  
Phone: 513-860-1785 Fax: 513-988-6521  
[www.greyfieldindustries.com](http://www.greyfieldindustries.com)

Power Requirements: 12VDC / 1A (center pin positive)  
 Lane Speaker: 4 Ohm / 10W (#3011)  
 Lane Microphone: Electret (#3010)

## 5003 AUDIO MATRIX

| FEATURE SWITCH                   | LEVER NO. | LEVER POSITION  |                  |
|----------------------------------|-----------|-----------------|------------------|
|                                  |           | UP (OFF)        | DOWN (ON)        |
| Lane Order *                     | 1         | <i>Normal</i>   | Reverse          |
| Not Used                         | 2         | X               |                  |
| Delayed Un-mute                  | 3         | No Delay        | <b>1 Second</b>  |
| Delayed Unmute                   | 4         | <b>No Delay</b> | <b>2 Seconds</b> |
| Not Used                         | 5         | X               |                  |
| Not Used                         | 6         | X               |                  |
| Echo Canceller Learning **       | 7         | <i>Dynamic</i>  | Fixed            |
| Background Noise Cancellation ** | 8         | Off             | On               |

\* Must be UP for 5501 series console

\*\* Applies to 5501 and most 5001 series consoles

### ADJUSTING TELLER CALL TONE TYPE / VOLUME

1. Press HOLD & LANE 1 keys at the same time to enter program mode. Lane 1 & 2 indicators will light orange.
2. Press LANE 2 key to rotate through call tone types until desired tone is heard.
3. Press LANE 1 key to rotate through the volume levels until desired level is reached.
4. Press the VOLUME DOWN key to select a single (1 beep) or repeating (2 beeps) call tone.
5. Press the HOLD key to exit programming mode.

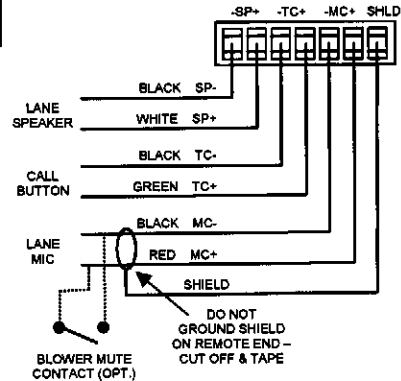
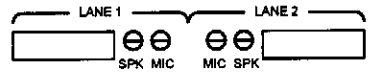

HFEA-5003LABEL (071807)

# Video

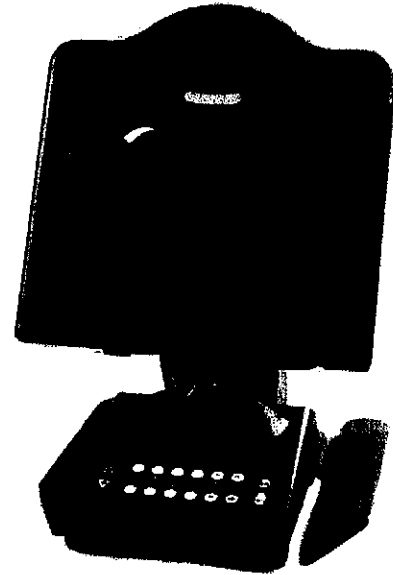
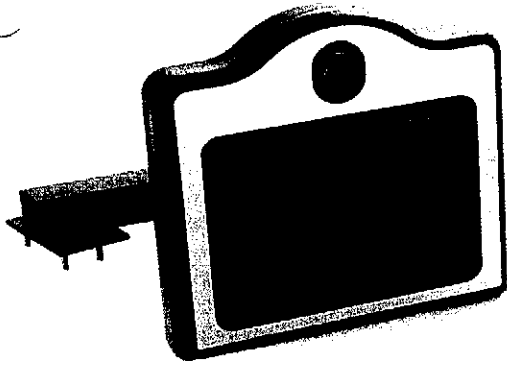

- **G5517 Customer video unit**
- **G5517-Sun Customer Video unit w/ sun viewable screen**
- **G5550 Indoor Desktop Video unit w/ camera**
- **G5550-1 Indoor Desktop Video Unit w/out camera**
- **One way and two way units available**
- **Weather Resistant outdoor unit**
- **Tamper resistant outdoor units**
- **Sun Viewable units available**
- **Large 10.5" LCD screen**
- **Play advertisements on customer screen**
- **Adjustable desktop stand included with indoor unit**
- **Optional wall mounting bracket & Swivel kit available which make the indoor units very user friendly**
- **Optional Adjustable Tilt Arm available for outdoor units**

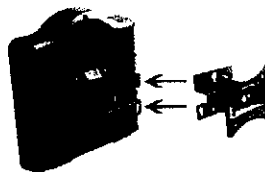

Greyfield Industries, Inc  
3104 Wayne-Madison Road, Trenton, Ohio 45067  
Phone: 513-860-1785 Fax: 513-988-9521  
[www.greyfieldindustries.com](http://www.greyfieldindustries.com)

# B5517 Remote Video Unit

---

The B5517 Remote Video Unit requires 12VDC at approximately 1.5A to operate properly. This requires that power be provided directly at the pneumatic unit to avoid the power drop associated with long wire runs. Each B5517 is supplied with a 12VDC, 2A power supply. An optional 5500 Video Power Control Kit (E0885), ordered separately, is used to control the relay board in each video head so the monitors, and optionally the cameras, can be turned off when desired. For larger installations it may be desirable to have more than one power control kit if some lanes are closed at times while other lanes are open.

- The video head will be positioned to the top right of the pneumatic unit as viewed by the customer. Use the enclosed template to drill holes in the top of the pneumatic unit for the bracket and cables. *(The template ensures that the video head will not stick out past the front of the pneumatic unit where it could be damaged by a vehicle.)*
- Feed the video cables, the 2A power supply cable and the relay trigger wires from the power control kit from inside the pneumatic unit through the top of the unit and through the video mounting bracket. Attach the mounting bracket to the pneumatic unit with the (4) supplied washers and nylon lock nuts.
- Remove the screws from the back of the video head and then remove the front cover. Note that not all screws for the cover are installed at the factory. The remaining screws are in the bag of accessories.
- Route the cables from the bracket through the back of the video head and up behind the monitor. *(Use care when fishing the wires behind the monitor to avoid damage to the circuit boards.)* Attach the video head to the mounting bracket with (4) screws provided in the accessory bag. Two of the screws are security type. A driver bit is included for the security screws.
- Connect the monitor cable to the top left BNC connector and the camera cable to the top right BNC connector in the video head as labeled. Connect the power supply cable and the relay trigger wires to the relay board near the top rear of the monitor per Figure 1 on the back of this document. Slide the excess cable back through the bracket and into the pneumatic unit and then install the end caps from the accessory bag into both ends of the bracket.
- Plug the power supply into a 110VAC outlet.
- Place the unit in “service” mode by placing the service switch at the upper left of the video head to the rear position. This will connect the camera video directly to the monitor. *Note: If the video power control kit in the teller area is not yet installed or turned on, it will be necessary to temporarily move the video power wires from the switched to the unswitched terminals of the relay board to test the video unit.*
- Tilt the camera vertically in its bracket to achieve the desired viewing angle. The camera has been focused at the factory and no further adjustment should be necessary. If focusing is required, loosen the small set screw on the side of the lens and then rotate the lens to the desired focus. Tighten the set screw when finished.
- No adjustments should be necessary to the monitor but a menu board with adjustment buttons is located directly under the screen for those familiar with adjusting LCD screens.
- Once all adjustments are satisfactory, place the unit in “normal” mode by placing the service switch to the forward position. Replace the front cover and secure using all the screws. Two of the screws are security type. A driver bit is included for the security screws.

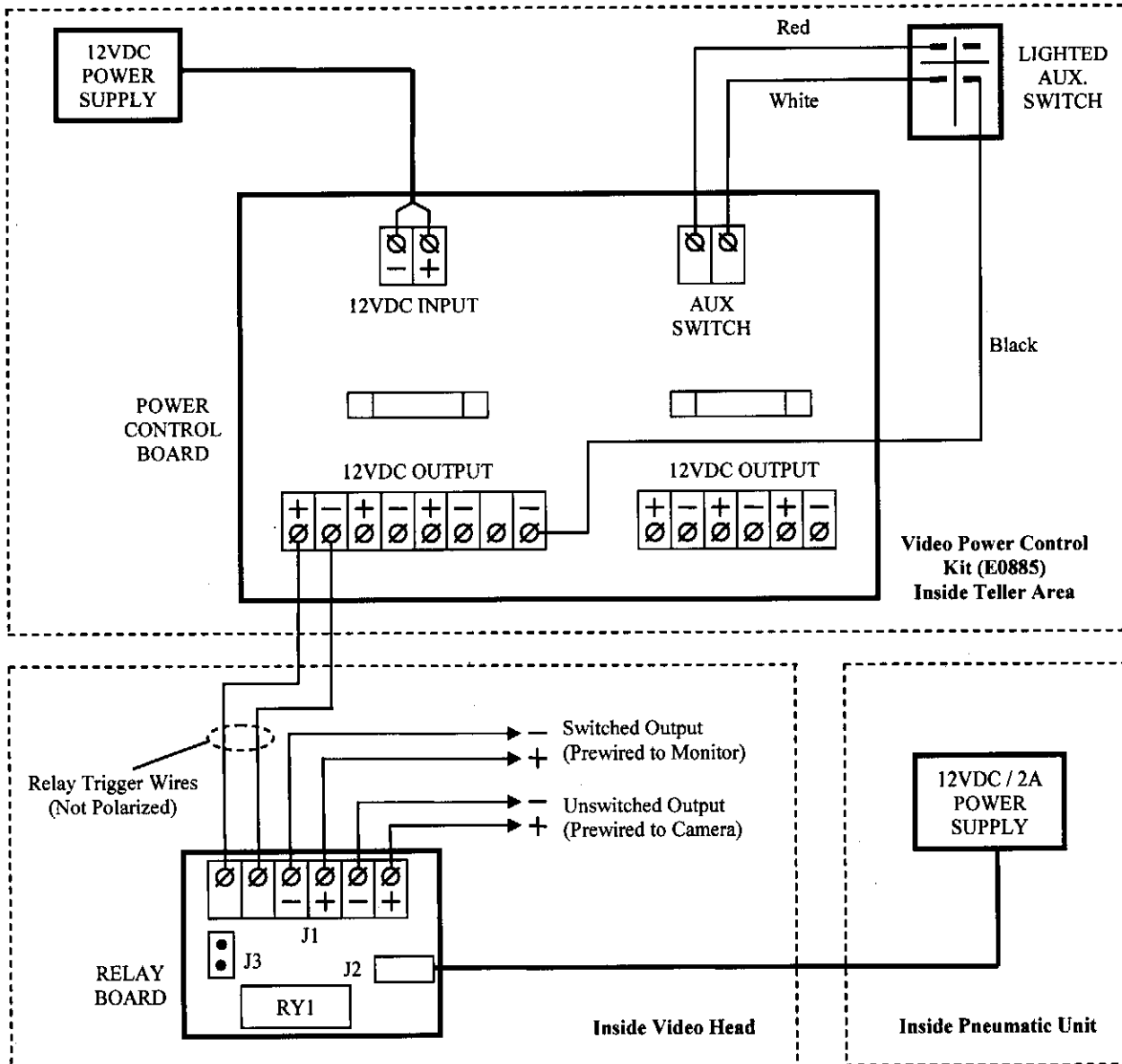

**Figure 1**

When using the Video Power Control Kit (E0885) shown above, be sure to follow the color code when connecting the lighted switch to the control board. The switch can be mounted in any suitable location, including the foot of one of the B5550 Teller Video Unit stands. The power control kit should only be used to control power to the relay boards in the video units as shown. **DO NOT** power video units directly with the power control kit.

The monitor power is prewired to the switched output and the camera power is prewired to the unswitched output of the relay board as shown. Move the wires as appropriate if your application is different. **(Be sure to unplug the power supply before changing any wiring on the relay board.)**

# B5550 Teller Video Unit

---

The following instructions are for the B5550 that contains both a camera and monitor for two way video. The B5550-1 is the same unit without a camera installed for one way video.

## Video & Power Connections

- Using 75 ohm CCTV coax (Belden 1426A or equivalent) with BNC connectors at each end, connect the camera and monitor (connections at rear of stand) to the video matrix. Make sure to match up the audio and video port numbers at the matrixes. For example if the audio console is connected to Console 2 of the audio matrix, then the video cables from that same teller position must be connected to Console 2 of the video matrix.
- Connect the supplied 12VDC power supply to the power socket on the back of the stand and plug it into a 110VAC outlet. If a different power supply must be used for some reason, it must be rated for at least 2A. The center conductor of the 2.1mm barrel connector is positive. Do not power this unit using the power distribution board which was previously used with the older B5450 unit. The B5550 requires approximately 1.5A of current per unit.

## Operation

- Turn on power to the video head using the toggle switch on the lower left of the stand.
- Adjust the height of the video head as necessary by first loosening the adjustment knob on the back of the stand. Tighten the knob when the desired height is achieved. Note that there are two holes in the back of the stand for the adjustment knob. Using the top hole the height can be adjusted between approximately 14.5"-19". Using the bottom hole the height can be adjusted between approximately 14.5"-16". The bottom hole also allows for a greater upward tilt angle at the lowest height allowing the video unit to be placed under a hanging pneumatic terminal if desired.
- Tilt the video head up by grasping the sides of the unit. The tilt latch bracket will lock the video head into place in steps. Tilt the head back down by first slightly tilting further up to release pressure on the tilt latch bracket and then pulling the handle of the bracket forward allowing the video head to drop down. Note that there are two holes in the top of the tilt latch bracket. Mounting the bracket using the opposite hole will allow the tilt angle to change slightly at each latch position.
- Use the lever beside the camera opening to tilt the camera up or down.

## Service Adjustments

- Service adjustments require access to the inside of the video head. Remove the 6 screws from the back side and remove the front cover.
- Place the unit in "service" mode by placing the service switch at the upper left of the video head to the rear position. This will connect the camera directly to the monitor. *Note that the service mode will result in a blank screen on the 5550-1 since no camera is present.*
- No adjustments should be necessary to the monitor but a menu board with adjustment buttons is located directly under the screen for those familiar with adjusting LCD screens.
- The camera has been focused at the factory and no adjustment should be necessary. If focusing is required, loosen the small set screw on top of the lens and then rotate the lens to the desired focus. Tighten the set screw when finished.
- Once all adjustments are satisfactory, place the unit in "normal" mode by placing the service switch to the forward position. Replace the front cover.

# Greyfield

# Air-Talk

## Wireless audio system

is an economical alternative when pulling cable is either impossible or too costly

**Greyfield's Air-Talk** is a full-duplex audio system for drive-thru and remote transaction applications. An Air-Talk installation requires no wiring and is especially convenient where you want to avoid the inconvenience and hazards of invasive construction.

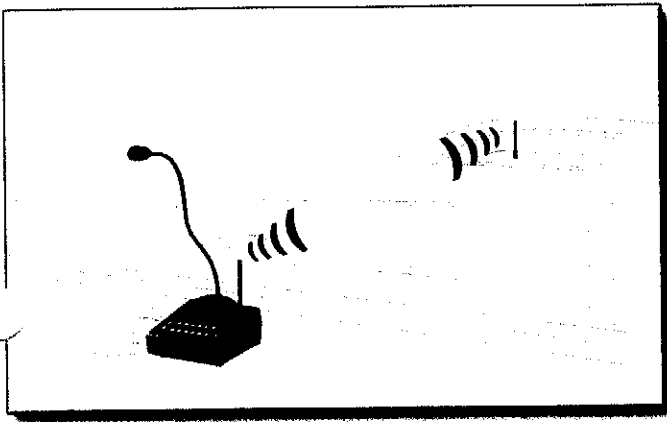

### Air-Talk Features include:

- Wireless audio, teller console to customer unit
- Noise cancellation circuitry for clear communications
- Integrated support for wireless headset systems that can make transactions faster and easier for customer service representatives
- Easy to install. One technician can install the module into an existing drive-up unit in approximately 30 minutes per lane
- Can serve up to four tellers and eight lanes with a maximum distance of 100 feet

5030 Wireless Audio Console and 5031LM Wireless Lane Module -- no audio cables are required to connect the teller console and the customer unit.



Model 5030  
Wireless Audio Console

# Greyfield

Greyfield Industries, Inc.  
3104 Wayne-Madison Road  
Trenton, Ohio 45067  
Phone: (513) 860-1785  
Fax: (513) 988-9521  
[www.greyfieldindustries.com](http://www.greyfieldindustries.com)

# Wireless Audio Console



- **Console part numbers G5030-2, G5030-4 and G5030-8**
  - **Completely Wireless Audio System**
  - **Full-duplex Intercom system**
  - **Supports any combination of 1 to 4 consoles**
  - **Will communicate with 1 to 8 drive-thru lanes**
  - **Background Noise Cancellation**
  - **Echo cancellation**
  - **Wireless Headset ready – no adaptor needed**
- 
- **Requires the G5031 Lane module for each customer lane.**
- 
- The G5031 Lane module is a small, rectangular device with a screen and a pen resting in front of it. It is used to interface with the wireless audio system for each customer lane.
- 
- **G5030-Kit Wireless Audio Sales Demo Kit is recommended before selling and installing a wireless system.**

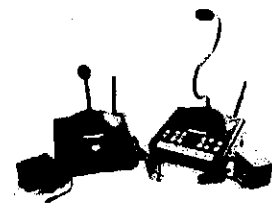

Greyfield Industries, Inc.  
3104 Wayne-Madison Road, Trenton, Ohio 45067  
Phone: 513-860-175 Fax: 513-988-9521  
[www.greyfieldindustries.com](http://www.greyfieldindustries.com)

# ***Air Talk 900™ Wireless Intercom*** **TIPS FOR INSTALLING THE PLANTRONICS CS50**

## **Introduction**

*Air Talk 900™* wireless audio consoles have integrated support for the Plantronics CS50 Wireless Office Headset System. This system offers crystal clear, secure communications. The headsets, with integrated battery, offer up to 8 hours of wireless, hands-free talk time and up to 300 feet of roaming distance.

## **Making the Connections to the CS50**

1. Connect the AC Power Adapter to the power jack on the bottom of the CS50.
2. Connect the provided short handset cable between the back of the *Air Talk 900™* audio console and the bottom of the CS50.
  - a. There are two handset jacks on the bottom of the CS50; you must use the one with the complete picture of the telephone, not just the picture of the telephone handset.

## **Initial Setup of the CS50**

1. There is a Configuration Dial on the left side of the CS50 - set this dial so that the number "1" is facing to the right.
2. Set the Master Speak Volume (outgoing volume) located on the bottom of the CS50 to the "B" position.
3. Set the Master Listen Volume (incoming volume) located on the back of the CS50 to the number "1" position.

## **Fine Tuning the CS50 Volumes**

1. Fine tune the outgoing speaker volume by using the up (+) and down (-) buttons on the back of the CS50 base.
2. Fine tune the incoming listen volume by using the small up and down button control located at the very back end of the boom portion of the teller headset.

## Other Hints when Using the CS50

1. When adjusting the volumes for the CS50 it is always best to *first* adjust the *Air Talk 900™* system without the CS50's installed. This will ensure that the volumes are normal and reasonable for the wireless headset system.
2. To switch between using the CS50 wireless headset and using the speaker and microphone located on the audio console, select the wireless button located on the console keypad. The wireless LED will light indicating when the unit is operating in CS50 headset mode. When operating in headset mode the local speaker and microphone are disabled.
3. Keep the CS50 wireless base-station as far away from the *Air Talk 900™* wireless console antenna as possible to avoid unnecessary interference between the two systems.
4. For most users, the CS50 will work best with the *Air Talk 900™* system when the headset is worn so the microphone boom is below the chin rather than in front of the user's mouth.

# Air Talk 900™

## Installation and Setup

**Note to Installers:** After installation, make sure this document is passed on to service personnel.

### Understanding the Air Talk 900™

#### *System Information and Basic Specifications*

The Air Talk 900™ is a wireless, full-duplex intercom system (audio only) that supports any combination of 1 to 4 audio consoles communicating with 1 to 8 drive-thru lanes. Thus, the system can be as simple as 1 audio console communicating with 1 lane or as complex as 4 audio consoles communicating with up to 8 lanes. The system consists of two basic modules; the **5030 Wireless Console** and the **5031 Wireless Lane Module**. The audio quality of the Air Talk 900™ is superb because of advanced audio processing features such as background noise cancellation, echo cancellation, and RF compression / expansion techniques. Below are the basic technical specifications for the Air Talk 900™ wireless intercom:

- Console Frequency: 925.5MHz (Tx), 904.5MHz (Rx) +/- 1.5MHz
- Lane Frequency: 904.5MHz (Tx), 925.5MHz (Rx) +/- 1.5MHz
- RF Channels: 20 at 150KHz spacing
- Antenna Impedance: 50 Ohm
- Line of Sight Range: 100 feet maximum
- Power Requirements for the 5030 Wireless Console
  - Voltage: 14Vdc +/- 2.5Vdc (center pin of barrel connector is +)
  - Current: 250mA maximum (8-lane keypad)
  - 200mA maximum (4-lane keypad)
- Power Requirements for the 5031 Wireless Lane Module
  - Voltage: 14Vdc +/- 2.5Vdc (center pin of barrel connector is +)
  - Current: 200mA idle, 250mA talk/idle, 350mA peak when talking
- 5030 Console FCC ID: UY5 5030AIRTALK900
- 5031 Lane Module FCC ID: UY5 5031AIRTALK900

#### *Understanding the Base Frequency and Communication Frequency*

The Air Talk 900™ utilizes a **base frequency** for communication between the 5030 wireless audio consoles and the 5031 wireless lane modules while in the *idle* state. Every console and lane module communicates on this base frequency.

When the wireless audio consoles and lane modules are in the *idle* state they are simply listening on the base frequency for commands. When a lane button is selected the wireless audio console sends a command requesting that the selected lane enter into a *private* communication session with the console. If the desired lane is present in the system, and is listening on the base frequency, the lane will acknowledge the command and both the wireless lane module and the requesting wireless audio console will switch to their own **private communication frequency**. All the other idle lanes and idle consoles will remain at the base frequency. When the teller hangs up, or puts the customer on hold, both sides will switch back to listening on the base frequency.

The private communication frequency is determined by the audio console number setup. The number for each audio console must be unique for proper operation of the system.

Because so much communication occurs on the base frequency it is important that the base frequency be free from interference. Thus, there are 4 possible base frequency settings which may be tested and / or changed in the maintenance setup mode. See the section **Maintenance Setup on the 5030 Console** for more information.

## Installation Procedure

### *Typical Installation Procedure*

The typical installation for the Air Talk 900™ is a very simple process consisting of the following steps:

1. Determine the desired number of 5030 consoles (1 to 4) and 5031 lane modules (1 to 8)
2. Setup a unique console number for each 5030
3. Connect power to the 5030 wireless consoles (*power supplies included*)
4. Setup the lane number for each 5031 wireless lane module
5. Mount the 5031 wireless lane modules & antennas
6. Connect the speaker, microphone & call button at each lane to the 5031 module
7. Connect power to the 5031 wireless lane modules (*power supplies included*)
8. Test the system and adjust as needed

**IMPORTANT: DO NOT change any jumper on the 5030 or 5031 boards that are not identified in this document unless directed by factory technical support personnel.**

### *Console Number Setup on the 5030 Wireless Console*

Every 5030 wireless audio console **MUST** have a unique console number. This includes consoles at one installation AND any other installation located within a 1000 foot radius. There are 16 unique console numbers available which are selected as follows:

Turn the rotary switch on the back of the audio console to any of the available 16 positions labeled 0 through F. The private communication Tx and Rx frequencies are listed in the table to the right.

*Application Note:* If the wireless audio console or customer lane is receiving interference from another RF source during teller to customer communications, try changing the console number to another one that is available. It is not necessary for the consoles to be numbered consecutively. **The console power must be cycled whenever the console number is changed.**

| Console # | Tx Freq (MHz) | Rx Freq (MHz) |
|-----------|---------------|---------------|
| 0         | 924.00        | 903.00        |
| 1         | 924.15        | 903.15        |
| 2         | 924.30        | 903.30        |
| 3         | 924.45        | 903.45        |
| 4         | 924.60        | 903.60        |
| 5         | 924.75        | 903.75        |
| 6         | 924.90        | 903.90        |
| 7         | 925.05        | 904.05        |
| 8         | 925.20        | 904.20        |
| 9         | 925.95        | 904.95        |
| A         | 926.10        | 905.10        |
| B         | 926.25        | 905.25        |
| C         | 926.40        | 905.40        |
| D         | 926.55        | 905.55        |
| E         | 926.70        | 905.70        |
| F         | 926.85        | 905.85        |

### *Lane Number Setup on the 5031 Wireless Lane Module*

Each 5031 wireless lane module within a particular system **MUST** be a unique number from 1 to 8. The lane number setup will determine which button will be pressed on the 5030 wireless audio console in order to communicate with the lane. Set jumpers W1 through W4 according to the chart below. After setting these jumpers, write the lane number on the cover of the module as indicated on the label.

| Lane # | W1  | W2  | W3  | W4  |
|--------|-----|-----|-----|-----|
| 1      | Off | Off | Off | Off |
| 2      | On  | Off | Off | Off |
| 3      | Off | On  | Off | Off |
| 4      | On  | On  | Off | Off |
| 5      | Off | Off | On  | Off |
| 6      | On  | Off | On  | Off |
| 7      | Off | On  | On  | Off |
| 8      | On  | On  | On  | Off |

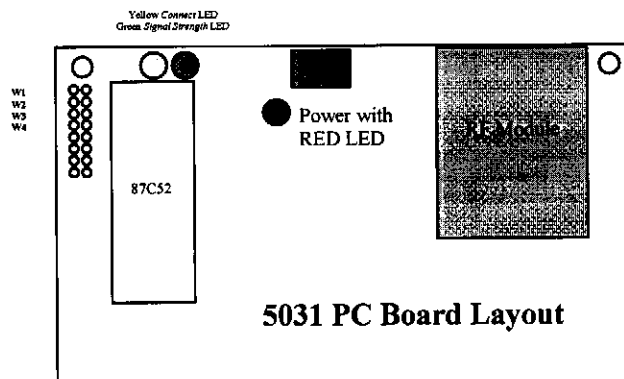

### Mounting the 5031 Lane Module and Antenna

1. Determine mounting locations for the 5031 lane module and antenna
  - Antenna cable length is 32"
  - Antenna should be mounted to the top of the pneumatic unit with an unobstructed view to the building
2. Drill a 1/4" hole in the top of the pneumatic unit for the antenna
3. Unthread the antenna from it's mounting stud
4. Mount both the lane module and antenna stud using appropriate hardware
  - The antenna cable must be routed to avoid any contact with moving parts of the pneumatic unit
5. Thread the antenna back onto it's mounting stud

### Wiring the 5031 Lane Module

The chart and drawing below show the wiring from the 5031 lane module to the speaker, call button, microphone, and optionally a traffic sense device. The wire colors in the chart apply to the pigtail cable which is supplied pre-wired to the connector. A traffic sense device, if used, should have a dry contact that closes to activate the input.

*Application Note:* The traffic sense input will cause the teller consoles to beep (if they are listening on the base frequency) but no lane LED will light. The console beep from a traffic sense input is different than the beep from a call button input. The call button would also flash the associated lane LED.

**IMPORTANT:** When retrofitting, it is necessary to disconnect the interconnect cabling from the old system before wiring the devices to the 5031 lane module. The two systems should never be wired in parallel.

| Signal Name | Description     | Wire Color |
|-------------|-----------------|------------|
| SPK-        | Speaker -       | Black      |
| SPK+        | Speaker +       | White      |
| TC-         | Call Button -   | Black      |
| TC+         | Call Button +   | Green      |
| MIC-        | Microphone -    | Black      |
| MIC+        | Microphone +    | Red        |
| TS-         | Traffic Sense - |            |
| TS+         | Traffic Sense + |            |

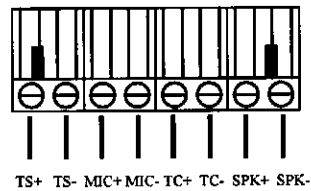

## Operation & Adjustment of the Air Talk 900™ System

### Keypad Operation of the 5030 Wireless Console

Operation information for end users is found on the label on the bottom of each 5030 console. The instructions below contain additional information about changing lane volume and entering maintenance mode. ***This information should generally not be given to end users to avoid possible mis-adjustment of the system.***

- To Talk to a Customer .....Press the LANE button
- To Put a Customer on Hold .....Press the HOLD button
- To Talk to a Customer on Hold .....Press the LANE button
- To Hang-up with a Customer .....Press the LANE button
- To Increase Console Volume (in steps).....Press VOLUME UP button while lane is selected
- To Decrease Console Volume (in steps) .....Press VOLUME DOWN button while lane is selected
- To Increase Lane Volume (in steps) \* .....Press HOLD-VOLUME UP buttons while lane is selected
- To Decrease Lane Volume (in steps) \* .....Press HOLD-VOLUME DOWN buttons while lane is selected
- \* DO NOT change lane volume until reading Adjusting Outgoing Lane Volume below.**
- To Toggle Noise Cancellation .....Press NOISE CANCEL button while lane is NOT selected
- To Toggle Wireless Headset Mode .....Press WIRELESS button while lane is NOT selected
- To Enter Maintenance Setup \*\* .....Press HOLD button for >3 seconds while lane is NOT selected
- \*\* DO NOT enter maintenance setup until reading the section Maintenance Setup on the 5030 Console later in this document.**

- SOLID GREEN Lane LED..... Lane is Selected by this console
  - BLINKING GREEN Lane LED ..... Customer is on Hold from this console
  - SOLID RED Lane LED \*\*\* ..... Lane is Selected by a different console
  - SLOW BLINKING RED Lane LED \*\*\* ...Lane is on Hold from a different console
  - FAST BLINKING RED Lane LED \*\*\* ..... Customer is Calling
- \*\*\* The lane status LED's on each console will only be updated while that particular console is listening on the base frequency. During the time a console is communicating with a lane on a private communication frequency, its status LED's will not be updated - for example when a different console selects a different lane.

#### *Adjusting Outgoing Lane Volume*

In most installations the outgoing lane volume can be left at factory default settings with no need for further adjustment. Keep in mind that the volume of the user's voice along with the distance from the microphone make a difference in the volume at the lane. If an adjustment is necessary, try the procedures below *in the order listed* until the desired volume is achieved.

- Begin by speaking directly into the console microphone at a distance of approximately 6". If the volume is too low, continue to move closer to the microphone until "teller echo" becomes objectionable. Optimal distance is just before teller echo begins. *Note: The distance between the lane speaker and microphone will make a big difference in the amount of teller echo in the system. Another factor is acoustical coupling (sound from the speaker bouncing around inside the enclosure of the unit being picked up by the microphone).*
- Puncture the black dot in the label on the bottom of the 5030 console and trim the microphone gain. This pot is factory set at 6 o'clock. As shown on the label, higher clock numbers increase the gain and lower clock numbers decrease the gain. Make slight adjustments of no more than one hour at a time and re-test.
- While communicating with a lane, press the HOLD and Volume UP or Volume DOWN arrow buttons at the same time to increase or decrease the lane volume one step. After pressing the buttons you will either hear a "high frequency" beep confirming that the volume change passed or a "low frequency" beep telling you that the volume change *may* have failed. Always test the volume level after each change attempt.

The outgoing lane volume level is stored in non-volatile memory in the 5031 lane module. If necessary, it is possible to return to the factory default level with the following procedure.

1. Remove power from the 5031 lane module and remove the cover from the enclosure.
2. Install the jumper across the pins of W19 which is located below the processor on the left side of the board.
3. Wait for the power up sequence to complete (loud static from the speaker) and then remove the jumper and replace the enclosure cover. *Note: If the jumper is not removed, the lane module will revert to the factory default volume level every time power is cycled to the module.*

## **5031 Diagnostic LED's**

The 5031 wireless lane module contains three diagnostic LED's that are defined as follows:

| <b>LED</b> | <b>GENERAL DESCRIPTION</b> | <b>ON</b>  | <b>OFF</b>                                       |
|------------|----------------------------|--|--|
| Red        | Power                      | Power is on                                      | Power is off                                     |
| Green      | Signal Strength *          | RF signal strength is above the preset threshold | RF signal strength is below the preset threshold |
| Yellow     | Connect                    | Lane is connected                                | Lane is idle                                     |

\* **Signal Strength Notes:**

1. The Green LED being ON means that the RF signal strength is very strong.
2. The Green LED being OFF does not necessarily mean that the signal strength is too low for quality communications but it does mean that the signal strength is not ideal.
3. It is normal for the Green signal strength LED to flicker during communications with a 5030 wireless audio console. However, it is not normal for the LED to be completely off during console communications.
4. If the Green LED is ON when the lane is not connected, that means there is another strong RF signal present in the area at the base frequency. This is a sign that there is the potential for RF interference at the base frequency resulting in poor performance of the system.

## **Communications Interference Test for the 5031**

When a jumper is placed on W18 of the 5031 (below the processor on the left side of the board), the board will enter a communications interference test. The wireless lane module will enter into a mode where it will transmit data out over and over again on *all* of the frequencies that may ever be used. The data is sent out on one frequency at a time until all of the frequencies have had data sent out and then the test will automatically start over again at the beginning.

The purpose of this test is that it permits an easy way to see if the 5031 wireless lane module will ever interfere with surrounding equipment. Place jumper W18 on and then test all other 900MHz equipment for possible interference.

The test may be stopped at any time by removing W18. It is easy to identify if the board is in test mode because the yellow diagnostic LED will turn on for a while, turn off, and then turn back on. This pattern will continue until the jumper is removed.

## **Maintenance Setup on the 5030 Console**

The wireless audio console is equipped with a maintenance setup mode that permits maintenance personnel to change and test base frequencies. See the section **Understanding the Air Talk 900™** before attempting to use maintenance setup.

### *Entering and Exiting Maintenance Setup*

- ❑ **To enter the maintenance setup mode** press the HOLD key for greater than 3 seconds. After entering maintenance setup the audio console will beep 1 to 4 times indicating the current base frequency number. Remember, there are 4 possible base frequencies. Additionally, while in maintenance setup the status LED's for lanes 1 and 2 will provide a visual indication of the base frequency. The following chart shows all base frequency information.

| Base Frequency # | Lane 1 LED | Lane 2 LED | # Beeps | Tx Freq (MHz) | Rx Freq (MHz) |
|------------------|------------|------------|---------|---------------|---------------|
| 1                | Blink      | Off        | 1       | 925.35        | 904.35        |
| 2                | Off        | Blink      | 2       | 925.50        | 904.50        |
| 3                | Blink      | Blink      | 3       | 925.65        | 904.65        |
| 4                | Green      | Green      | 4       | 925.80        | 904.80        |

- ❑ **To exit the maintenance setup mode** press the HOLD key while not performing a test.

### Base Frequency Communication Test with Any Lane

While in maintenance setup mode it is possible to perform a base frequency communication test with any lane as follows:

- To start the test select the desired lane
- A steady high frequency beep pattern means each communication attempt passed
- An unsteady high frequency beep pattern means some communication attempts had to be re-sent (signal strength is marginal or the signal is being interrupted)
- A low frequency beep means the communication attempt failed
- To stop the test for that lane press and hold the lane button until the beeping stops

### Changing the Base Frequency

Each 5030 console and 5031 lane module ships from the factory preset for base frequency #1. This programming is stored in non-volatile memory so it is retained while the module is powered down. In most installations the base frequency will not need to be changed. However, if interference exists with some other 900MHz equipment, such as the audio system from a fast food restaurant next door, you should be able to correct the problem by changing the base frequency. *Don't automatically assume the base frequency needs changed. If the interference only happens when using one particular console, try changing the console number first. (See the section Console Number Setup on the 5030 Wireless Console)*

If changing the base frequency is necessary, it is recommended to experiment using one console and one lane module. Once a suitable base frequency is found, the other lane modules and consoles can then be changed to match. Remember that the entire system needs to be set to the same base frequency. **Please read the entire procedure that follows before attempting any changes to avoid confusion. It is assumed at this point that signal strength is not an issue. This should have been verified before installation.**

1. Enter setup mode and determine the current base frequency for the console by the number of beeps and LED status as shown in the chart on the previous page.
2. To change the base frequency on **both the console and the lane module**, press and hold down the lane key until you hear a status beep. A high frequency beep indicates the base frequency change attempt passed and a low frequency beep indicates the base frequency change attempt failed. *NOTE: A low frequency beep also means the console and lane module may no longer be at the same base frequency. Perform a base frequency communication test by selecting the appropriate lane (see the procedure Base Frequency Communication Test with Any Lane above). If necessary change the base frequency of only the console (see step 4) and retest the communications. Repeat until communication is re-established.*
3. Repeat step 2 to change the base frequency on each remaining lane module. Either use a different console in the system which is still on the old base frequency, or change the original console back to the old base frequency (see step 4). *Remember that the console and lane module must both be on the same base frequency before a change can be made to the lane module.*
4. To change the base frequency on the **console only**, press the VOLUME UP key. The console will beep 1 to 4 times indicating the new base frequency. Also see the chart for the LED status.
5. Exit setup mode by pressing the HOLD key while no test is being performed.
6. Test the operation of each lane with each console in the system for proper operation. Remember that all consoles and lane modules in the system must be set to the same base frequency.

# Air Talk 900™ Demo Kit

***For more information, and to avoid confusion, please review the “Air Talk 900™ Installation and Setup” document to understand the system before using the demo kit.***

The demo kit consists of the following items:

- 5030 Wireless Console – The console is programmed at the factory for base frequency #1. A 12Vdc / 1A power supply is included.
- 5031 Wireless Lane Module – The lane module for the demo kit is installed in a modified console enclosure with a pre-wired speaker, microphone and call button. The module is programmed at the factory for lane #1 and base frequency #1. A power cord is supplied which can be plugged into the cigarette lighter socket in a vehicle. An additional 12Vdc / 1A power supply is also included for using the lane module indoors.

The demo kit should be tried at the job site **before** selling the Air Talk 900™ system to test for adequate signal strength, interference issues, and audio quality. Two people will be required.

- The console should be tested while positioned at each teller station.
- The lane module should be tested by driving up to each lane. The module assembly can be placed on the existing pneumatic unit, placed on the vehicle dash, or held out the window of the vehicle.
- A base frequency communication test should be run for each lane. (See the section **Maintenance Setup on the 5030 Console** on pages 5 & 6 of the installation and setup document.) If possible, have a second vehicle drive between the console and lane being tested to see if communications are interrupted. *Note: A canopy over the lanes helps to reflect the signal around line-of-sight obstructions. Different canopy materials have varying effects.*
- If the outgoing lane volume needs to be changed, follow the procedures **in order** as outlined on page 4 of the installation and setup document. *Note: Jumper W19, as outlined in the document, is factory installed on the demo lane module so the speaker volume at the lane will return to the factory default level each time power is cycled to the module.*

# ***New!***

## **Audio Accessories**

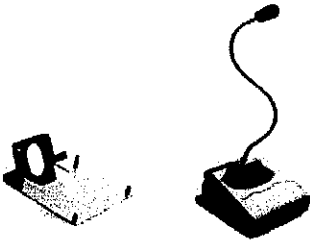

Vesa Horizontal Wall Bracket..... Part# **G5501-HWB**



Vertical Wall Bracket  
for G5500 Series Consoles .....Part# **G5501-VWB**



Red Handset Kit  
(Used w/ G5501-VWB sold separately).....Part # **GB6074-KITR**



Black Handset Kit  
(Used w/ G5501-VWB sold separately).....Part# **GB6074-KITB**

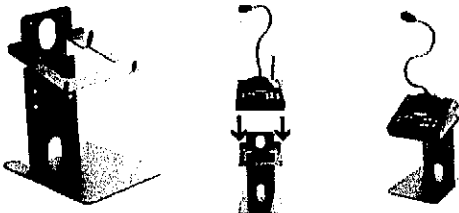

Adjustable Desktop G5500 Console Stand .....Part# **GB6077**

## **Now Available!**



# ***New!***

## **Video Accessories**



### **Adjustable Tilt Arm for G5517 Customer Video Monitor** **Part# GB6712**

*Allows the outside customer screen to be angled up or down for easier viewing.*

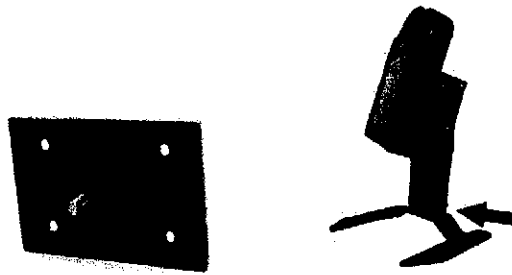

### **G5550 Swivel Kit** **Part# GB6075**

*Allows the teller video screen to swivel from side to side.*

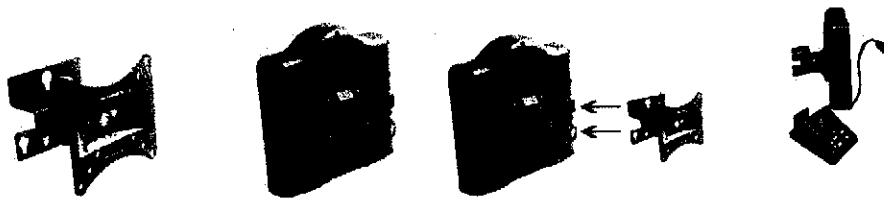

### **Adjustable Vesa Wall Bracket** **Part# GH3655**

*Mounts the teller video screen to the wall and is used with the G5501-HWB which mounts the teller consoles to the wall. Using both mounts eliminates the need for any counter space!*

**\*Now Available\***

## Greyfield Audio/Video Frequently Asked Questions

---

### Audio

Q. Why is there sometimes a “gurgling” sound from the incoming audio of a 5000 series audio console?

A. The audio processor used in 5000 series audio consoles has built in background noise cancellation. This feature works well to reduce constant and consistent background sounds such as idling vehicles or loud mufflers. However when the background noise is constantly changing, such as traffic noise from a nearby busy street, the processor can't keep up with the changes. This will cause a side effect that most people describe as an under water or gurgling sound. Vehicles sitting in front of a deal drawer have also been known to cause this symptom at some locations due to the sound bouncing between the building and vehicle, although this may not occur with all vehicles. The symptom gets worse as the gains on the matrix pots are increased, the volume adjustment on the console is increased, or the level of the background noise increases due to conditions such as heavier traffic or the presence of large trucks. Note that this “watery” sound is left over background noise and it should have no affect on the customer’s voice at the lane.

Q. Is it possible to turn off the background noise cancellation feature of a 5000 series audio console?

A. Older 5001 consoles have background noise cancellation enabled at all times and it is not possible to turn it off. Later 5001 consoles and all 5501 consoles allow the ability to toggle this feature on/off on a console by console basis. With 5001 consoles press the volume up arrow while no lane is selected. The model number of the console determines which LED’s indicate the status when this feature is toggled but in all cases GREEN = ON and RED = OFF. The indicator is as follows:

5001-1 .....Lane 1 LED

5001-2 .....Lane 1 & 2 LED’s

5001-6 .....Lane 1 & 2 LED’s

5001-12 .....Lane 1 & 3 LED’s

All 5501 consoles have a dedicated noise cancel button & LED and also allow the feature to be toggled while a lane is selected. Keep in mind that turning background noise cancellation off will allow all noise at the lane to be heard, including a noisy vehicle or traffic noise.

Q. Every time there is even a momentary power outage, the status of background noise cancellation changes from the preferred status on 5000 series audio consoles. Can anything be done about that?

A. Feature switch #8 on the audio matrix determines the initial status of background noise cancellation for all consoles any time the system goes through a reset, such as cycling power to the matrix or plugging in a console while the matrix is already powered up. The default status is as follows:

Switch 8 DOWN .....Background Noise Cancellation ON (Factory Setting)

Switch 8 UP .....Background Noise Cancellation OFF

For 5001-1 consoles which have no matrix, switch #2 on the main board inside the console has this same effect. *Note that older versions of 5001 consoles have background noise cancellation enabled at all times and it cannot be turned off.*

Q. When a lane is selected using a 5000 series audio console, why are the first few words from the customer sometimes hard to understand?

A. To answer this question it is necessary to explain the echo canceller feature in the 5000 series consoles. Since these consoles operate in full duplex, the teller’s voice going out the customer speaker is picked up by the customer microphone which then comes back through the teller speaker. The result is the teller hearing their own voice. The echo canceller in the 5000 series consoles works to reduce that effect. The echo canceller can have either dynamic or fixed learning. Dynamic

learning adjusts to its environment each time a teller selects a lane whereas fixed learning stays at a factory preset value. Dynamic learning can cause what some people describe as “robot voice” in certain environments when the lane is initially selected and then clears up after “learning” has been accomplished which could take a few seconds. Fixed learning will eliminate this condition but the echo canceller will not work as well so there will be more of a tendency for the teller to hear their own voice coming back through the console speaker. This condition will be worse with higher settings of the speaker/mic pots on the matrix or when customer units have their speaker and microphone in close proximity to each other. The varying acoustics from sound bouncing off the customer’s vehicle also has an effect. The type of learning is determined by feature switch #7 on the audio matrix as follows:

Switch 7 UP .....DYNAMIC Echo Canceller Learning (Factory Setting)

Switch 7 DOWN .....FIXED Echo Canceller Learning

For 5001-1 consoles which have no matrix, switch #1 on the main board inside the console has this same effect. Be sure to cycle power to the system any time this switch is changed. *Note that older versions of 5001 consoles have varying degrees of “learning” and this switch may not operate the same.*

Q. The teller can hear their own voice through the console speaker when certain lanes are selected. Also there is sometimes feedback. What can be done to prevent this?

A. Any console that operates in full duplex can exhibit these problems if the customer speaker and microphone are too close together and the volume levels are too loud. Sound bouncing off the customer vehicle also contributes to this. 5000 series consoles have an echo canceller feature which reduces the effect of this condition. See the previous question for more information on the echo canceller. It is also possible that the wrong type of cabling was used from the matrix to the lane. If a shielded pair is not used for the microphone there can be enough capacitive coupling from the speaker wires to the microphone wires to cause these problems since the microphone operates with an extremely small amount of current. NEVER use a 6 conductor cable with an overall shield.

Q. What is the proper cable to use from the audio matrix to the customer lanes?

A. Greyfield offers a cable (GE0680) that is ideal for this application. It has a 16AWG twisted, unshielded pair for the speaker, a 20AWG twisted, unshielded pair for the call button and a 20AWG twisted, shielded pair for the microphone. Be sure to use 16AWG wire for the speaker if different cabling is used. Heavier speaker wire may be needed for distances over 180 feet. The microphone wire must be a twisted, shielded pair. The shield must be attached to terminal 7 of the lane connector on the matrix but cut off and taped at the customer end. Also be sure to ground the matrix.

Q. I have an installation with a long cable run and I can’t get adequate outgoing volume to the customer lane. It would be very difficult to pull a larger wire gauge speaker cable. Do I have any other option?

A. A lane speaker driver kit (GE0892-KIT) is available and allows GE0680 audio cable to be extended to 1000 feet. The driver board in the kit presents a high impedance to the audio matrix which results in much lower current (less loss) across the speaker wires. 12VDC is required to power the board. If this voltage is not available in the unit you can use the power supply that is included with the kit; although a 110VAC outlet would then be required.

Q. What is the proper power supply to use with the various matrixes?

A. The proper power supply to use with each audio matrix is listed below. Video matrixes get their power from the audio matrix via the modular cable that is supplied with each video matrix. Likewise audio consoles get their power through their modular cables. ***Do not power cameras, monitors or any other device with the same power supply that is connected to the matrix.***

**Matrix**

**Power Supply**

|  |   |
|--|---|
| 5002-4 (and older 4 lane matrixes) .....   | GE0736 (12VDC, 5.5A)                        |
| 5002-8 (and older 8 lane matrixes) .....   | GE0736 (12VDC, 5.5A)                        |
| 5002-12 (and older 12 lane matrixes) ..... | GE0736 (12VDC, 5.5A)                        |
| 5004 (and older 2 lane matrixes) .....     | GE0947 (12VDC, 1A) – Included with matrix   |
| 5006 (and older 2 lane matrixes) .....     | GE0947 (12VDC, 1A) – Included with matrix   |
| 5003.....                                  | G571-001 (12VDC, 1A) – Included with matrix |

Q. Is it possible to replace a defective console with a different model or series of console?

A. Generally speaking the answer is yes, but observe the following guidelines:

- Consoles within the same series can be substituted but the number of available lanes may be affected. For example, a 12-lane console could be used on a 2-lane matrix but only the first 2 lanes on the console would work. Likewise, a 2-lane console could be used on a 12-lane matrix but only the first two lanes would be available with that console.
- Consoles within the same series but of different revisions may not have exactly the same features. For example, a newer 5001 console has the ability to turn off background noise cancellation while an older 5001 console may not. Also the echo canceller “learning” may work differently.
- If there are multiple teller stations in a system, be aware of possible issues when mixing consoles from different series on a permanent basis. Besides feature differences, each series of console has a different quality of audio and may require different level settings with the matrix speaker & mic pots. It may be difficult to adjust the system for optimal performance with all consoles.
- A 5501 console will not work if it is substituted into a system that has the lane order reversed. This is determined by feature switch #1 on the audio matrix. This switch must be set to the up (normal) position when using 5501 consoles.
- If a 3000 series matrix is being used, it is recommended to only use 3000 series consoles. A 5000 series console may have issues at times such as a delay when selecting a lane or having to select a lane twice before it works. A 4000 series console may completely lock up.
- 3001-1, 4001-1 and 5001-1 consoles are stand-alone systems and they will not work with a matrix. *Don't be confused by the small interconnect board which is not a matrix.* The interconnect board for the 4001-1 or 5001-1 will work with either console. The interconnect board for the 3001-1 will only work with that console.

Q. Is it possible to replace a defective audio matrix with a different model of audio matrix?

A. Generally speaking the answer is yes, but observe the following guidelines:

- 4000 and 5000 series audio matrixes can replace each other with no problems even if the system has video. A 4000 series audio matrix will work fine with a 5000 series video matrix or vice versa.
- 4000 and 5000 series audio matrixes can replace 3000 series audio matrixes if the system does not have video. The communications and cabling to a 3000 series video matrix is different than 4000 or 5000 series video matrixes so in this case it would be necessary to replace both the audio and video matrixes.
- 3000 series audio matrixes should not be used to replace 4000 or 5000 series audio matrixes because of possible console issues – see the previous question. Also it would not be compatible with a 4000 or 5000 series video matrix.
- Whenever replacing an older matrix with a new one be sure to check the power supply. Older Samlex power supplies (3A or 10A) can develop problems as they age. As the capacitors dry out

there will be AC ripple on the DC output. Also these power supplies are listed as 13.6VDC but the output has been known to rise as high as 18VDC or more as they age. This will cause equipment failures. The recommended power supply to use is GE0736 which is much smaller and rated at 12VDC, 5.5A.

Q. How can I change the call tone or call tone volume?

A. The instructions can be found on the audio matrix label but are listed below for reference. Any console in the system can be used to program these items.

1. Press the LANE 1 key while pressing the HOLD key. Lane 1 & 2 indicators will light orange.
2. Press the LANE 2 key to rotate through the call tone types until the desired tone is heard.
3. Press the LANE 1 key to rotate through the volume levels until the desired level is heard.
4. Press the ▼ key to select a single call tone (1 beep) or repeating tones (2 beeps).
5. Press the HOLD key to exit programming mode.

The instructions above are for all systems that have an audio matrix. The 3001-1, 4001-1 and 5001-1 consoles have a volume control for the call tone which is accessible from the bottom of the unit. The call tone type cannot be changed on these consoles.

Q. What do the switches on the audio matrix do?

A. The switches are identified on the audio matrix label but are listed below in greater detail for reference. Factory settings are shown in bold type.

| Feature                                    | Switch # | Switch Position         |                      |
|--|----------|-------------------------|----------------------|
|  |          | UP (OFF)                | DOWN (ON)            |
| Lane Order <sup>1</sup>                    | 1        | <b>Normal</b>           | Reverse              |
| Console Limit <sup>2</sup>                 | 2        | <b>2 Per Lane</b>       | 1 Per Lane           |
| Delayed Unmute <sup>3</sup>                | 3        | No Delay                | <b>1 Second</b>      |
| Delayed Unmute <sup>3</sup>                | 4        | <b>No Delay</b>         | 2 Seconds            |
| Aux. Audio Mode <sup>4</sup>               | 5        | <b>Normal</b>           | Noise Abate          |
| Call Tone Default <sup>5</sup>             | 6        | <b>Normal</b>           | Erase                |
| Echo Canceller <sup>6</sup>                | 7        | <b>Dynamic Learning</b> | Fixed Learning       |
| Background Noise Cancellation <sup>6</sup> | 8        | Off At Startup          | <b>On At Startup</b> |

<sup>1</sup> Determines whether the console lane buttons work from left to right (normal) or right to left (reverse). This switch must be UP for 5501 series consoles.

<sup>2</sup> Determines if more than one console can select the same lane at the same time. Volume levels will be reduced when multiple consoles select the same lane. This switch has no effect with a 5003 matrix.

<sup>3</sup> The mute circuit is wired so the closure of an auxiliary contact of the blower relay shorts across the lane microphone to mute the incoming audio while the blower is running. These switches determine the length of delay after the microphone short is removed until the incoming audio comes back on. The switches can be combined to give a 3 second delay.

<sup>4</sup> Noise Abate mutes the auxiliary audio (if used) until the call button is pressed or the lane is put on hold. This feature is generally used if the facility is near a housing development to prevent complaints from the residents. This switch has no effect with a 5003 matrix.

<sup>5</sup> This determines whether the call tone programming goes back to factory default (erase) when the system goes through a reset or whether the programming is saved (normal). The programming is always saved with a 5000 series audio matrix regardless of the position of this switch.

<sup>6</sup> These switches as listed are for features in 5000 series consoles. They are explained in detail in previous questions in this document.

- Q. Why are the MIC DC switches not present on the current 5000 series audio matrixes?
- A. These switches were used to set the type of customer lane microphone. The switch needed to be set to the down (DC) position for electret microphones and to the up position for dynamic microphones. It was somewhat common for these switches to be set wrong during installation and then the lane microphones would not work. For this reason, and because it is extremely rare that dynamic microphones are used, the switches have been omitted and the matrix boards have been internally set to the DC position. If it is absolutely necessary to use dynamic microphones with these matrixes contact Finetech Tech Support at 877-236-0245 for guidance.
- Q. What are the requirements for the auxiliary audio input on the matrix?
- A. This is a standard line level input like you would find on the output of a computer sound card. A level adjustment next to the RCA connectors on the matrix controls the volume. Left and right channel connectors allow for connection to a stereo source but they will be mixed together for a mono output at the customer lane. If a mono source is used, either input on the matrix can be used.
- Q. The console cable that ships with each audio console is too short for a particular installation. Can I make a longer cable without causing problems?
- A. This cable has been tested at lengths up to 50 feet with no problems. Use standard category 5 cable with wire colors matching at each RJ45 connector. Contact Finetech tech support (877-236-0245) for guidance if greater lengths are needed.
- Q. I have a problem site where the matrix and/or audio consoles are failing prematurely. Sometimes cycling power to the system will cause it to start working again. What could be happening?
- A. You should start by checking for power problems, especially if this is an old building. "Dirty" power with voltage spikes or current surges can cause all kinds of problems with electronic equipment. Static electricity also causes problems and is generally more likely during the winter months. All consoles with a metal chassis should have a ground wire (16AWG or larger) attached at the rear to help divert static around the components. Attach the ground wire to the best ground source available. An electrical ground is usually adequate. In severe cases it may be necessary to use static mats or take other means to prevent static from happening. 5501 series consoles are less likely to be affected by static electricity than any of the other consoles.
- Q. I have received complaints that customers using the handset with a remote unit can hear other tellers speaking to other customers. What could cause this?
- A. There are multiple things to consider for this issue as follows.
- (1) Contact Finetech Tech Support (877-236-0245) with the model and serial number of the matrix to determine if that matrix needs a modification. Also look for any stickers on the matrix indicating an upgrade was performed at the Finetech repair center.
  - (2) If the handset board is a model 4012, remove the yellow wire coming from the handset and add a 6.8k resistor in series with the wire.
  - (3) If the handset board is a model 5012, look for resistor R11 near the terminal strip. If a jumper wire is installed instead of a resistor either replace the jumper with a 6.8k resistor or add the resistor in series with the yellow handset wire as in step 2.
  - (4) Adjust the speaker & mic gain pots on the matrix using the local speaker and microphone in the remote unit, **not** the handset. Keep the gains as low as possible without the audio being too weak. Since the remote units using handsets are often installed indoors it is not necessary, nor desirable, for the speaker volume to be very loud.

- (5) Lift the handset off the cradle and adjust the gain pots on the 5012 / 4012 board for adequate volume with the handset. As before, don't set the volumes louder than necessary.
- (6) If the tellers sometimes use headsets don't overlook the possibility that the headsets are not adjusted properly resulting in excessive volume at the remote unit.

Q. I am installing a Plantronics CS50 wireless headset to an audio console and I can't get it to work. What could be wrong?

A. One possibility is the phone cable is plugged into the wrong jack on the base unit of the CS50. Be sure to use the jack with the picture of a complete telephone, not the handset jack. It's also possible that the 5014 wireless interface adapter is being used where it is not needed. Many newer 5001 consoles and all 5501 consoles have a phone jack next to the RJ45 matrix cable jack. With these consoles the base unit of the wireless headset should plug directly into the console and the 5014 should not be used. Consoles without the phone jack will require the 5014. In this case the pins from the 5014 may not be making proper contact in the phono jacks of the console. Open up the console and loosen the 3 screws that hold the console board to the bottom of the chassis. Slide the board to the rear and tighten the screws. Plug the 5014 in and out of the console several times to help clean the contacts which may have gotten dirty or corroded over the years. It is also highly recommended to use the sheet metal screw that is supplied with each 5014 to secure it to the console. This is especially important with 5001-1 consoles. A slot in the 5014 allows the console ground wire to attach using the same screw.

Q. How do I change from console to headset use when the console is not using the 5014 adapter?

A. With 5001 consoles the camera button on the keyboard is also the wireless button. While no lane is selected this button will toggle between console mode and wireless headset mode. A yellow LED directly under the microphone boom indicates wireless mode. 5501 consoles have a dedicated button for this purpose. The yellow LED is next to the button.

Q. What is the proper procedure for adjusting the CS50 wireless headset?

A. 1. Make sure to first adjust the lane speaker & mic pots on the matrix for proper levels using the console mode, not the wireless mode.  
2. Set the master talk switch on the bottom of the CS50 base to the B position.  
3. Set the master listen switch on the back of the CS50 base to the 2 position.  
4. Set the console to the wireless mode and then use the fine tune adjustments on the CS50 to balance the audio levels to match the console mode. The + and - buttons on the back of the base are for fine tuning the talk volume. The roll switch on the headset adjusts the listen volume.

Q. My Plantronics CS50 wireless headset quit working and causes a loud static sound at the customer lane. What could be wrong?

A. Power surges or static electricity are the most likely causes of this symptom according to Plantronics tech support. Use the following steps to reset the headset and correct the problem.  
1. Press both the talk button and the mute control button on the headset for 5 seconds. (The mute control is the volume control pressed in.)  
2. When the talk indicator light on the headset blinks, release both buttons.  
3. Press the talk button again.  
4. Remove power from the base unit for 5 seconds and then power it back up.

Q. I have two sites with wireless headsets. At one location the teller call tones come through the headset and at the other site the call tones come through the console speaker. Why is this?

- A. This has to do with the circuitry of the console board and whether it has a built-in wireless headset jack. Newer 5001 and all 5501 consoles have the built-in jack and the teller call tone will always come through the console, even when it is in headset mode. Consoles that do not have this jack require the 5014 adapter to connect a wireless headset. With most of these consoles the call tone will only sound through the headset while the toggle switch is in headset mode. It is not possible to change how this works on a given console since the board design is the determining factor.
- Q. Is there any other wireless headset system available for the Greyfield audio consoles besides the Plantronics CS50?
- A. There are many different wireless headsets on the market from various manufacturers and most of them would probably work fine but the only one currently sold by Greyfield is the Plantronics CS50. Another one that is known to be compatible is the GN Netcom GN9330. This unit has a user replaceable spare battery with charger available as an option. It also allows a different headset to be quickly linked to the base with the push of a button. Follow the link below for more information on this product. <http://www.jabra.com/sites/jabra/na-us/products/pages/jabrag9330.aspx>. Note that Greyfield cannot guarantee compatibility with other headsets, so try them at your own risk.

### Video

- Q. Is it possible to use audio and video matrixes from different series together on the same system?
- A. 4000 and 5000 series audio and video matrixes can be interchanged. 3000 series audio matrixes can only be used with 3000 series video matrixes since the communications and cabling are different.
- Q. I have an application requiring one-way video. Is a video matrix available for one-way use only?
- A. All video matrixes currently manufactured are bidirectional. For one-way video just use the lane camera and console monitor connectors.
- Q. What are the dip switches on the end of the video matrix for?
- A. The dip switches set features in the video matrix as follows. Factory default settings are shown **bold**.

| Feature                      | Switch # | Switch Position      |                    |
|------------------------------|----------|----------------------|--------------------|
|                              |          | UP (OFF)             | DOWN (ON)          |
| Idle Console View            | 1        | Driveway Camera Only | <b>All Cameras</b> |
| Auxiliary Video <sup>1</sup> | 2        | Normal               | <b>Static</b>      |
| Not Used                     | 3        | <b>X</b>             |                    |
| Lane Shift <sup>2</sup>      | 4        | <b>Normal</b>        | Shifted            |
| Not Used                     | 5        | <b>X</b>             |                    |

<sup>1</sup> The static position generally works best for most video signals. If the auxiliary video does not work, try the normal position.

<sup>2</sup> This switch causes the lane numbers on the video matrix to be associated with the next higher lane number on the audio matrix. For example, assume a facility has 5 lanes of audio with lane 1 being a deal drawer and lanes 2 through 5 being pneumatic units. If video was only being used on the pneumatic units you could get by with a 4-lane video matrix by shifting the lanes on the video matrix so they would be associated with audio lanes 2 through 5.

- Q. What are the requirements for the auxiliary video input on the video matrix?
- A. This input requires an industry standard 1V peak to peak composite video signal, the same as the output from a CCTV camera. Typical sources for this signal are the video output of a DVR or a computer that has a video card with a composite video output.

Q. I just installed a video matrix that I know is good but one or more teller monitors will not lock in on any lane camera when that lane is selected. What could be wrong?

A. Make sure that the teller positions match up on the audio and video matrixes. For example if an audio console is plugged into CONSOLE 2 of the audio matrix, the camera and monitor for that teller must be plugged into CONSOLE 2 of the video matrix. Also make sure that the termination switches are set properly for each lane camera and the driveway camera (see the following question).

Q. When a teller selects a particular lane, the teller monitor either doesn't lock in on that lane camera or it will lock in initially but then start cycling between lanes again. The problem may be intermittent and not all lanes may be affected. What causes this?

A. The termination switches, labeled TERM, are probably not set properly for each lane camera and the driveway camera on the video matrix. These switches terminate the cable at 75 ohms which is required for the end of the run for any CCTV signal. If the cable from the camera "terminates" at the video matrix, the switch should be ON. If there is a t-tap at the video matrix to send the camera signal on to some other device, such as a DVR, the switch should be OFF because the end of the run is now the DVR and the termination should happen there. Keep in mind that the video signal will still be reduced any time a t-tap is used. If the DVR has true looping outputs, meaning the signal is regenerated, it would be best to run the cables from the lane cameras to the DVR first and then terminate them at the video matrix. When troubleshooting this type of problem on a system that has t-taps, and the termination switches are set properly, try removing the t-taps temporarily and terminate the cables at the matrix. If the system works properly at this point, the problem may be weak outputs from the cameras or signal loss from long cable runs. It is also possible that the DVR was not terminating the cable properly. Also make sure that the coax cable is intended for CCTV and that 75 ohm BNC connectors are being used. Belden 1426A is a very good cable to use for this application and should work for cable runs up to about 800 feet.

Q. I just installed one or more 5517 customer video units and the monitors won't work. What could be wrong?

A. The power supply for each 5517 connects to a relay module near the top of the video unit. The camera power is prewired to the unswitched output and the monitor power is prewired to the switched output of the relay module. A GE0885 Video Power Control Kit is normally used to control the relays from inside the facility so the monitors can be turned off after hours. If this kit is not being used, or not yet installed, simply move the monitor power wires to the unswitched output of the relay board.

Q. I just installed 5550 teller video units or 5517 customer video units and the monitors always show the camera from that unit. What could be wrong?

A. The most likely cause is the service switch inside the unit being in the service position. In this mode the video cables leaving the unit are disconnected and the camera is internally connected directly to the monitor.

Q. I just installed 5550 teller video units or 5517 customer video units. The monitors worked at first but now I cannot get a picture. What could be wrong?

A. If a blue box appears on the screen with a message that says "AV No Signal", the monitor is working but it is not receiving a video signal. If the message says "SV No Signal" or "VGA No Signal" the video input source has been changed. The left button on the adjustment board which is mounted in the top left of the unit changes the source. Press this button to cycle through the choices to get the input set for AV.